

JSIMA 適用区分表

レベル
セオドライト
トータルステーション
光波測距儀
レーザ測量機器
レーザ受光器
GNSS測量機器

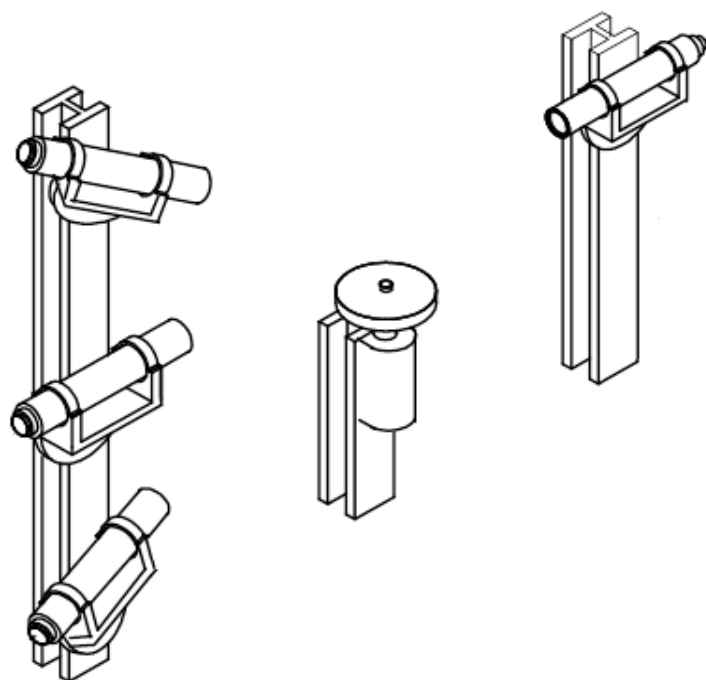

本書は、日本測量機器工業会規格に準拠して、JSIMA適用区分について記してあります。
●本書の作成時における最新版の日本測量機器工業会規格に準拠して記載しています。
●日本測量機器工業会規格や測定方法等の詳細は日本測量機器工業会規格に準拠して下さい。

JSIMA 適用区分表**レベル**

型名	公称値			適用区分
	倍率	気泡管感度	自動補正範囲	
L-10	42 x	10 "/2mm	—	A
L-20	32 x	20 "/2mm	—	B
L-30/E	32 x	40 "/2mm	—	C
AL-2	32 x	—	±10'	B
AL-3	22 x	—	±10'	C
AL-6B	20 x	—	±12'	D
PAL-2/S/C/CR/R	32 x	—	±12'	B
PAL-3C/CR/R	28 x	—	±12'	B
PAL-5C/CR	24 x	—	±12'	C
AL-M2/S/C/R	32 x	—	±12'	B
AL-M4/C/R	27 x	—	±12'	B
AL-M5C/CR	24 x	—	±12'	C
AL-M24	24 x	—	±15'	C
AL-M28	28 x	—	±15'	B
AL-M30	30 x	—	±15'	B
AL-M32	32 x	—	±15'	B
AL-180	18 x	—	±12'	D
AL-200	20 x	—	±12'	D
AL-220	22 x	—	±12'	D
AL-240B	24 x	—	±12'	D
AL-240/R	24 x	—	±12'	C
AL-270/R	27 x	—	±12'	B

型名	公称値			適用区分
	倍率	気泡管感度	自動補正範囲	
AL-300	30 x	—	±12'	B
AL-320/S/R	32 x	—	±12'	B
AL-241/R	24 x	—	±12'	C
AL-271/R	27 x	—	±12'	B
AL-301	30 x	—	±12'	B
AL-321/S/R	32 x	—	±12'	B
AP-020	20 x	—	±15'	D
AP-022	22 x	—	±15'	D
AP-024	24 x	—	±15'	D
AP-120	20 x	—	±15'	D
AP-124	24 x	—	±15'	D
AP-128	28 x	—	±15'	C
AP-241	24 x	—	±15'	D
AP-281	28 x	—	±15'	C
AP-226	26 x	—	±15'	C
AP-230	30 x	—	±15'	C
AFL-240	24 x	—	±12'	C
AFL-280	28 x	—	±12'	B
AFL-320/R	32 x	—	±12'	B
AFL-241	24 x	—	±12'	C
AFL-281	28 x	—	±12'	B
AFL-321/R	32 x	—	±12'	B

JSIMA 適用区分表**セオドライト**

型名	公称値			三軸補正 の有無	適用区分	角度読取方式	
	最小読取值	標準偏差	高度補正範囲			水平	鉛直
FG-1B	20"	—	—	—	C (V:D)	両	片
TH-01/W	1"	—	±5'	—	A	両	両
TH-06D	6"	—	±5'	—	B	両	片
TH-10D/DC	10"	—	±5'	—	B	両	片
TH-20D	20"	—	±5'	—	C	両	片
TH-20DC	20"	—	—	—	C	両	片
FX-1DC	20"	—	—	—	C	片	片
FX-20DC	20"	—	—	—	C	両	片
PD-20/C	10"	—	—	—	C	両	両
TH-E10C/D	20"	7"	—	—	C	両	片
TH-E20C	20"	10"	—	—	C	片	片
ETH-05A	10"/5"	5"	±3'	—	B	両	両
ETH-10C/D	10"/5"	7"	—	—	C	両	両
ETH-20C	20"/10"	10"	—	—	C	片	片
ETH-105A	10"/5"	5"	±3'	—	B	両	両
ETH-107C	10"/5"	7"	—	—	C	両	両
ETH-110C	20"/10"	10"	—	—	C	片	片
ETH-120C	20"/10"	20"	—	—	C	片	片
ETH-210/C	20"/10"/5"	10"	—	—	C	両	片
ETH-220/C	20"/10"	20"	—	—	C	両	片

JSIMA 適用区分表**セオドライト**

型名	公称値			三軸補正 の有無	適用区分	角度読取方式	
	最小読取值	標準偏差	高度補正範囲			水平	鉛直
ETH-307C	5"/1"	7"	±3'	—	C	両	片
ETH-310C	10"/5"	10"	—	—	C	両	片
ETH-320C	20"/10"	20"	—	—	C	両	片
ETH-407C	5"/1"	7"	±3'	—	C	両	片
ETH-410C	10"/5"	10"	—	—	C	両	片
ETH-420C	20"/10"	20"	—	—	C	両	片
ETH-507C	5"/1"	7"	±3'	—	C	両	両
ETH-510C	10"/5"	10"	—	—	C	両	片
ETH-520C	20"/10"	20"	—	—	C	両	片

JSIMA 適用区分表**トータルステーション(セオドライト部)**

型名	公称値			三軸補正 の有無	適用区分	角度読取方式	
	最小読取值	標準偏差	高度補正範囲			水平	鉛直
PX-06D	6"	—	±5'	—	B	両	片
PX-10D/DC	10"	—	±5'	—	B	両	片
PX-20DC	20"	—	±5'	—	C	両	片
PTS-10	5"	5"	±3'	—	B	両	片
PTS-20/C	10"	10"	±3'	—	C	両	片
PTS-II 05/C	5"	5"	±3'	—	B	両	片
PTS-II 10/C	10"	7"	±3'	—	C	両	片
PTS-II 20C	20"/10"	10"	—	—	C	片	片
PTS-III 05/C	5"/1"	3"	±3'	—	B	両	片
PTS-III 10/C	10"/5"	5"	±3'	—	B	両	片
PTS-505/C	5"/1"	3"	±3'	有	B	両	両
PTS-510/C	10"/5"	5"	±3'	—	B	両	両
PTS-520/C	20"/10"	7"	±3'	—	C	両	両
PTS-603/C	5"/1"	3"	±3'	有	B	両	両
PTS-605/C	10"/5"	5"	±3'	—	B	両	両
PTS-607C	20"/10"	7"	±3'	—	C	両	両
RS-20/C	20"/10"	10"	—	—	C	片	片
RS-201/C/B	20"/10"	10"	—	—	C	片	片
PCS-110/C	10"/5"	5"		—	B	両	片
PCS-120C	20"/10"	7"	±3'	—	C	両	片
ITS-011	5"/1"	3"	±3'	—	B	両	両
ITS-051/C	5"/1"	3"	±3'	—	B	両	両
ITS-101/C	10"/5"	5"	±3'	—	B	両	両
P-270c	20"/10"	7"	±3'	—	C	片	片

JSIMA 適用区分表

トータルステーション(セオドライト部)

型名	公称値			三軸補正 の有無	適用区分	角度読取方式	
	最小読取值	標準偏差	高度補正範囲			水平	鉛直
P-360c	20"/10"	6"	±3'	-	B	片	片
R-105N/C	10"/5"	5"	±3'	-	B	両	両
R-106N/C	20"/10"	6"	±3'	-	B	両	両
R-205N/C	10"/5"	5"	±3'	-	B	両	両
R-206N/C	20"/10"	6"	±3'	-	B	両	両
R-303N/NC	5"/1"	3"	±3'	有	B	両	両
R-303NS/NSC	5"/1"	3"	±3'	有	B	両	両
R-303/C	5"/1"	3"	±3'	有	B	両	両
R-305N/NC	10"/5"	5"	±3'	-	B	両	両
R-305NS/NSC	10"/5"	5"	±3'	-	B	両	両
R-306N/NC	20"/10"	6"	±3'	-	B	両	両
R-306NS/NSC	20"/10"	6"	±3'	-	B	両	両
R-306/C	20"/10"	6"	±3'	-	B	両	両
R-316C	20"/10"	6"	±3'	-	B	両	両
R-317C	20"/10"	7"	-	-	C	両	両
R-330N/NC	5"/1"	3"	±3'	有	B	両	両
R-330/C	5"/1"	3"	±3'	有	B	両	両
R-350N/NC	10"/5"	5"	±3'	-	B	両	両
R-350/C	10"/5"	5"	±3'	-	B	両	両
R-360N/NC	20"/10"	6"	±3'	-	B	両	両
R-360/C	20"/10"	6"	±3'	-	B	両	両
R-361C	20"/10"	6"	±3'	-	B	両	両
R-430N/NC	5"/1"	3"	±3'	有	B	両	両
R-450N/NC	10"/5"	5"	±3'	-	B	両	両
R-460N/NC	20"/10"	6"	±3'	-	B	両	両
R-430NM/NMC	1"/5"	3"	±3'	有	B	両	両
R-450NM/NMC	5"/10"	5"	±3'	-	B	両	両

JSIMA 適用区分表

トータルステーション(セオドライト部)

型名	公称値			三軸補正 の有無	適用区分	角度読取方式	
	最小読取值	標準偏差	高度補正範囲			水平	鉛直
R-460NM/NMC	10"/20"	6"	±3'	-	B	両	両
R-530NS/NSc	1"/5"	3"	±3'	有	B	両	両
R-550NS/NSc	5"/10"	5"	±3'	-	B	両	両
R-560NS/NSc	10"/20"	6"	±3'	-	B	両	両
V-260NC	20"/10"	6"	±3'	-	B	片	片
V-270C	20"/10"	7"	±3'	-	C	片	片
V-271C	20"/10"	7"	±3'	-	C	片	片
V-270NSc	10"/5"	5"	±3'	-	B	両	両
V-270Pc	10"/20"	6"	±3'	-	B	両	両
V-270NScX	10"/5"	5"	±3'	-	B	両	両
V-280NSc	10"/5"	5"	±3'	-	B	両	両
V-280Pc	10"/20"	6"	±3'	-	B	両	両
V-350NC	10"/5"	5"	±3'	-	B	両	片
V-360C	10"/20"	6"	±3'	-	B	片	片
V-350DN	10"/5"	5"	±3'	-	B	両	片
V-360DNC	20"/10"	6"	±3'	-	B	片	片
V-450N/NC	10"/5"	5"	±3'	-	B	両	片
V-450DN/DNC	10"/5"	5"	±3'	-	B	両	片
V-460c/DNc	20"/10"	6"	±3'	-	B	片	片
V-450NSc	10"/5"	5"	±3'	-	B	両	両
V-460Pc	10"/5"	6"	±3'	-	B	両	両
V-550NSc	10"/5"	5"	±3'	-	B	両	両
V-560Pc	10"/5"	6"	±3'	-	B	両	両

JSIMA 適用区分表**トータルステーション(セオドライト部)**

型名	公称値			三軸補正 の有無	適用区分	角度読取方式	
	最小読取值	標準偏差	高度補正範囲			水平	鉛直
W-830N	5"/1"	3"	±3'	有	B	両	両
W-850N/NC	5"/10"	5"	±3'	-	B	両	両
W-860N/NC	5"/10"	6"	±3'	-	B	両	両
X-105NS/NSc	5"/1"	5"	±3'	-	B	両	両
X-105DNS/DNSc	5"/1"	5"	±3'	-	B	両	両
P-106Nc	10"/5"/1"	5"	±3'	-	B	両	両
P-206Nc	10"/5"/1"	5"	±3'	-	B	両	両

JSIMA 適用区分表

光波測距儀・トータルステーション(EDM部)

※1:レーザー測距機のみ

型名	公称値(プリズム/シート※1)		公称値(ノンプリ)		適用区分
	測距精度(10m以上)	測距精度(1.5m~10m)	測距精度(10m以上)	測距精度(1.5m~10m)	
PM-81	±(5+5ppm × D)mm	±(5+5ppm × D)mm	-	-	B
MD-14	±(5+5ppm × D)mm	±(5+5ppm × D)mm	-	-	B
MD-20	±(5+5ppm × D)mm	±(5+5ppm × D)mm	-	-	B
PX-06D	±(5+5ppm × D)mm	±(5+5ppm × D)mm	-	-	B
PX-10D/DC	±(5+5ppm × D)mm	±(5+5ppm × D)mm	-	-	B
PX-20DC	±(5+5ppm × D)mm	±(5+5ppm × D)mm	-	-	B
PTS-10	±(5+5ppm × D)mm	±(5+5ppm × D)mm	-	-	B
PTS-20	±(5+5ppm × D)mm	±(5+5ppm × D)mm	-	-	B
PTS-II 05/C	±(5+3ppm × D)mm	±(5+3ppm × D)mm	-	-	B
PTS-II 10/C	±(5+3ppm × D)mm	±(5+3ppm × D)mm	-	-	B
PTS-II 20C	±(5+3ppm × D)mm	±(5+3ppm × D)mm	-	-	B
PTS-III 05/C	±(5+3ppm × D)mm	±(5+3ppm × D)mm	-	-	B
PTS-III 10/C	±(5+3ppm × D)mm	±(5+3ppm × D)mm	-	-	B
PTS-505/C	±(3+2ppm × D)mm	±(3+2ppm × D)mm	-	-	A
PTS-510/C	±(3+2ppm × D)mm	±(3+2ppm × D)mm	-	-	A
PTS-520/C	±(3+2ppm × D)mm	±(3+2ppm × D)mm	-	-	A
PTS-603/C	±(3+2ppm × D)mm	±(3+2ppm × D)mm	-	-	A
PTS-605/C	±(3+2ppm × D)mm	±(3+2ppm × D)mm	-	-	A
PTS-607C	±(3+2ppm × D)mm	±(3+2ppm × D)mm	-	-	A
RS-20/C	±(5+3ppm × D)mm	±(5+3ppm × D)mm	-	-	B
RS-201/C/B	±(3+2ppm × D)mm	±(3+2ppm × D)mm	-	-	A
PCS-110/C	±(3+2ppm × D)mm	±(3+2ppm × D)mm	-	-	A
PCS-120C	±(3+2ppm × D)mm	±(3+2ppm × D)mm	-	-	A

JSIMA 適用区分表

光波測距儀・トータルステーション(EDM部)

※1:レーザー測距機のみ

型名	公称値(プリズム/シート※1)		公称値(ノンプリ)		適用区分
	測距精度(10m以上)	測距精度(1.5m~10m)	測距精度(10m以上)	測距精度(1.5m~10m)	
ITS-011	±(3+2ppm × D)mm	±(3+2ppm × D)mm	-	-	A
ITS-051/C	±(3+2ppm × D)mm	±(3+2ppm × D)mm	-	-	A
ITS-101/C	±(3+2ppm × D)mm	±(3+2ppm × D)mm	-	-	A
R-105N/NC	±(3+2ppm × D)mm	±(5+2ppm × D)mm	±(4+2ppm × D)mm	±(5+2ppm × D)mm	A
R-106N/NC	±(3+2ppm × D)mm	±(5+2ppm × D)mm	±(4+2ppm × D)mm	±(5+2ppm × D)mm	A
R-205N/NC	±(3+2ppm × D)mm	±(5+2ppm × D)mm	±(4+2ppm × D)mm	±(5+2ppm × D)mm	A
R-206N/NC	±(3+2ppm × D)mm	±(5+2ppm × D)mm	±(4+2ppm × D)mm	±(5+2ppm × D)mm	A
R-303N/NC	±(3+2ppm × D)mm	±(5+2ppm × D)mm	±(4+2ppm × D)mm	±(5+2ppm × D)mm	A
R-303NS/NSC	±(3+2ppm × D)mm	±(5+2ppm × D)mm	±(4+2ppm × D)mm	±(5+2ppm × D)mm	A
R-303/C	±(3+2ppm × D)mm	±(5+2ppm × D)mm	-	-	A
R-305N/NC	±(3+2ppm × D)mm	±(5+2ppm × D)mm	±(4+2ppm × D)mm	±(5+2ppm × D)mm	A
R-305NS/NSC	±(3+2ppm × D)mm	±(5+2ppm × D)mm	±(4+2ppm × D)mm	±(5+2ppm × D)mm	A
R-305/C	±(3+2ppm × D)mm	±(5+2ppm × D)mm	-	-	A
R-306N/NC	±(3+2ppm × D)mm	±(5+2ppm × D)mm	±(4+2ppm × D)mm	±(5+2ppm × D)mm	A
R-306NS/NSC	±(3+2ppm × D)mm	±(5+2ppm × D)mm	±(4+2ppm × D)mm	±(5+2ppm × D)mm	A
R-306/C	±(3+2ppm × D)mm	±(5+2ppm × D)mm	-	-	A
R-316C	±(3+2ppm × D)mm	±(5+2ppm × D)mm	-	-	A
R-317C	±(3+2ppm × D)mm	±(5+2ppm × D)mm	-	-	A
R-330N/NC	±(2+2ppm × D)mm	±(3+2ppm × D)mm	±(4+2ppm × D)mm	±(5+2ppm × D)mm	A
R-330/C	±(2+2ppm × D)mm	±(3+2ppm × D)mm	-	-	A
R-350N/NC	±(2+2ppm × D)mm	±(3+2ppm × D)mm	±(4+2ppm × D)mm	±(5+2ppm × D)mm	A
R-350/C	±(2+2ppm × D)mm	±(3+2ppm × D)mm	-	-	A
R-360N/NC	±(2+2ppm × D)mm	±(3+2ppm × D)mm	±(4+2ppm × D)mm	±(5+2ppm × D)mm	A
R-360/C	±(3+2ppm × D)mm	±(3+2ppm × D)mm	-	-	A
R-361C	±(3+2ppm × D)mm	±(3+2ppm × D)mm	-	-	A
R-430N/Nc	±(2+2ppm × D)mm		±(4+2ppm × D)mm	±(5+2ppm × D)mm	A
R-450N/Nc	±(2+2ppm × D)mm		±(4+2ppm × D)mm	±(5+2ppm × D)mm	A
R-460N/Nc	±(2+2ppm × D)mm		±(4+2ppm × D)mm	±(5+2ppm × D)mm	A

JSIMA 適用区分表

光波測距儀・トータルステーション(EDM部)

※1:レーザー測距機のみ

型名	公称値(プリズム/シート※1)		公称値(ノンプリ)		適用区分
	測距精度(10m以上)	測距精度(1.5m~10m)	測距精度(10m以上)	測距精度(1.5m~10m)	
R-430NM/NMc	±(2+2ppm × D)mm	±(3+2ppm × D)mm	±(5+2ppm × D)mm		A
R-450NM/NMc	±(2+2ppm × D)mm	±(3+2ppm × D)mm	±(5+2ppm × D)mm		A
R-460NM/NMc	±(2+2ppm × D)mm	±(3+2ppm × D)mm	±(5+2ppm × D)mm		A
R-530NS/NSc	±(2+2ppm × D)mm	±(3+2ppm × D)mm	±(3+2ppm × D)mm	±(5+2ppm × D)mm	A
R-550NS/NSc	±(2+2ppm × D)mm	±(3+2ppm × D)mm	±(3+2ppm × D)mm	±(5+2ppm × D)mm	A
R-560NS/NSc	±(2+2ppm × D)mm	±(3+2ppm × D)mm	±(3+2ppm × D)mm	±(5+2ppm × D)mm	A
V-260Nc	±(3+2ppm × D)mm	±(5+2ppm × D)mm	±(4+2ppm × D)mm	±(5+2ppm × D)mm	A
V-270c	±(3+2ppm × D)mm	±(5+2ppm × D)mm	-	-	A
V-271c	±(3+2ppm × D)mm	±(5+2ppm × D)mm	-	-	A
V-270NSc	±(2+2ppm × D)mm	±(3+2ppm × D)mm	±(3+2ppm × D)mm	±(5+2ppm × D)mm	A
V-270Pc	±(2+2ppm × D)mm	±(3+2ppm × D)mm	-	-	A
V-270NScX	±(2+2ppm × D)mm		±(3+2ppm × D)mm	±(5+2ppm × D)mm	A
V-280NSc	±(2+2ppm × D)mm	±(3+2ppm × D)mm	±(3+2ppm × D)mm	±(5+2ppm × D)mm	A
V-280Pc	±(2+2ppm × D)mm	±(3+2ppm × D)mm	-	-	A
V-350NC	±(2+2ppm × D)mm	±(3+2ppm × D)mm	±(4+2ppm × D)mm	±(5+2ppm × D)mm	A
V-360C	±(3+2ppm × D)mm	±(3+2ppm × D)mm	-	-	A
V-350DN	±(2+2ppm × D)mm	±(3+2ppm × D)mm	±(4+2ppm × D)mm	±(5+2ppm × D)mm	A
V-360DNC	±(3+2ppm × D)mm	±(3+2ppm × D)mm	±(4+2ppm × D)mm	±(5+2ppm × D)mm	A
V-450N/Nc	±(2+2ppm × D)mm	±(3+2ppm × D)mm	±(4+2ppm × D)mm	±(5+2ppm × D)mm	A
V-450DN/DNc	±(2+2ppm × D)mm	±(3+2ppm × D)mm	±(4+2ppm × D)mm	±(5+2ppm × D)mm	A
V-460c/DNc	±(2+2ppm × D)mm	±(3+2ppm × D)mm	-	-	A
V-450NSc	±(2+2ppm × D)mm	±(3+2ppm × D)mm	±(4+2ppm × D)mm	±(5+2ppm × D)mm	A
V-460Pc	±(2+2ppm × D)mm	±(3+2ppm × D)mm	-	-	A

JSIMA 適用区分表

光波測距儀・トータルステーション(EDM部)

※1:レーザー測距機のみ

型名	公称値(プリズム/シート※1)		公称値(ノンプリ)		適用区分
	測距精度(10m以上)	測距精度(1.5m~10m)	測距精度(10m以上)	測距精度(1.5m~10m)	
V-550NSc	±(2+2ppm x D)mm	±(3+2ppm x D)mm	±(4+2ppm x D)mm	±(5+2ppm x D)mm	A
V-560Pc	±(2+2ppm x D)mm	±(3+2ppm x D)mm	-	-	A
W-830N	±(2+2ppm x D)mm	±(3+2ppm x D)mm	±(4+2ppm x D)mm	±(5+2ppm x D)mm	A
W-850N/NC	±(2+2ppm x D)mm	±(3+2ppm x D)mm	±(4+2ppm x D)mm	±(5+2ppm x D)mm	A
W-860N/NC	±(2+2ppm x D)mm	±(3+2ppm x D)mm	±(4+2ppm x D)mm	±(5+2ppm x D)mm	A
X-105NS/NSc	±(2+2ppm x D)mm	±(3+2ppm x D)mm	±(4+2ppm x D)mm	±(5+2ppm x D)mm	A
X-105DNS/DNSc	±(2+2ppm x D)mm	±(3+2ppm x D)mm	±(4+2ppm x D)mm	±(5+2ppm x D)mm	A
P-106Nc	±(2+2ppm x D)mm	測距精度(2m~10m) ±(2+2ppm x D)mm	測距精度(5m~200m) ±(3+2ppm x D)mm 測距精度(200m~600m) ±(3+2ppm x D)mm	測距精度(2m~5m) ±(10+2ppm x D)mm	A
P-206Nc	±(2+2ppm x D)mm	測距精度(2m~10m) ±(2+2ppm x D)mm	測距精度(5m~200m) ±(3+2ppm x D)mm 測距精度(200m~600m) ±(3+2ppm x D)mm	測距精度(2m~5m) ±(10+2ppm x D)mm	A

JSIMA 適用区分表**レーザー測量機器**

型名	種類	公称値		JSIMAの適用区分
		水平(総合)精度	上方鉛直精度	
PLP-2	水平回転レーザー	±10''	—	A
PLP-3	水平回転レーザー	±15''	—	B
PLP-5H	水平回転レーザー	±10''	—	A
PLP-50	水平回転レーザー	±12''	—	B
PLP-70C	水平・鉛直複合回転レーザー	±10''	15''	A
PLP-70R	水平・鉛直複合回転レーザー	±10''	15''	A
PG-3A	パイプレーザー	±10''	—	A
PG-3B	パイプレーザー	±10''	—	A
PG-5A	パイプレーザー	±10''	—	A
PG-5B	パイプレーザー	±10''	—	A
PLP-601	水平回転レーザー	±10''	—	A
PLP-602	水平回転レーザー	±12''	—	B
PLP-60A	水平回転レーザー	±12''	—	B
PLP-701	水平回転レーザー	±10''	—	A
PLP-702	水平回転レーザー	±12''	—	B
PLP-115	水平・鉛直複合回転レーザー	±15''	±20''	B
PLP-115G	水平・鉛直複合回転レーザー	±15''	±20''	B
PLP-201	水平回転レーザー	±10''	—	A
PLP-202	水平回転レーザー	±15''	—	B

JSIMA 適用区分表**レーザ受光器**

型名	種類	検出幅(公称値)				備考
		Hi	middle	Lo	Lowest	
LS3	受光器	0~3mm	-	3~7mm	-	PLP-2/3/5H/50シリーズ
LS6	受光器	0.8~2mm	-	3.5~6.5mm	-	PLP-600・70シリーズ
LS7・6A	受光器	0.8~2mm	-	3.5~6.5mm	-	PLP-700・60Aシリーズ
LS10	受光器	1~3mm	-	2~5mm	-	PLP-202
LS10D	受光器(デジタル)	0~3mm	0~4mm	3~10mm	4~20mm	PLP-201

JSIMA 適用区分表

GNSS測量機器

型名	種類	公称値(RTK GPS観測精度)		JSIMAの適用区分
		X/Y(総合)精度	Z軸精度	
PS9500D	GNSS	±10mm±1ppm以下	±20mm±1ppm以下	1級
PS9400S	GNSS	±10mm±1ppm以下	±20mm±1ppm以下	2級
SMT888-3G	GNSS	±10mm±1ppm以下	±20mm±1ppm以下	1級
G3100-R1B/R	GNSS	±10mm±1ppm以下	±20mm±1ppm以下	1級
G3100-R2	GNSS	±10mm±1ppm以下	±20mm±1ppm以下	1級
G6Ni	GNSS	±10mm±1ppm以下	±20mm±1ppm以下	1級
G6J	GNSS	±10mm±1ppm以下	±20mm±1ppm以下	1級
G6J2	GNSS	±10mm±1ppm以下	±20mm±1ppm以下	1級
G7N	GNSS	±10mm±1ppm以下	±20mm±1ppm以下	1級
GX2-A	GNSS	±10mm±1ppm以下	±20mm±1ppm以下	1級
GX2-C	GNSS	±10mm±1ppm以下	±20mm±1ppm以下	1級
GX2-L	GNSS	±10mm±1ppm以下	±20mm±1ppm以下	1級